



# IECEx Certificate of Conformity

## INTERNATIONAL ELECTROTECHNICAL COMMISSION IEC Certification System for Explosive Atmospheres

for rules and details of the IECEx Scheme visit [www.iecex.com](http://www.iecex.com)

Certificate No.: **IECEx PRE 20.0124X** Page 1 of 3 [Certificate history:](#)

Status: **Current** Issue No: 0

Date of Issue: 2021-03-03

Applicant: **METALMECH ENGINEERING**  
Plot No. 4246, GIDC, Dared,  
Phase - III, Road No. E,  
Jamnagar, Gujarat 361 004  
India

Equipment: **A Range of Compression Type Cable Glands**

Optional accessory:

Type of Protection: **Ex d, Ex e, Ex t**

Marking: **Ex db IIC Gb**  
**Ex eb IIC Gb**  
**Ex tb IIIC Db**  
**Ambient temperature: -55°C to +160°C**

Approved for issue on behalf of the IECEx  
Certification Body:

**Asle Kaastad**

Position:

**Certification Manager**

Signature:  
(for printed version)

Date:

\_\_\_\_\_  
\_\_\_\_\_

1. This certificate and schedule may only be reproduced in full.
2. This certificate is not transferable and remains the property of the issuing body.
3. The Status and authenticity of this certificate may be verified by visiting [www.iecex.com](http://www.iecex.com) or use of this QR Code.



Certificate issued by:

**DNV Product Assurance AS**  
**Veritasveien 3**  
**Hovik 1363**  
**Norway**





# IECEX Certificate of Conformity

Certificate No.: **IECEX PRE 20.0124X**

Page 2 of 3

Date of issue: 2021-03-03

Issue No: 0

Manufacturer: **METALMECH ENGINEERING**  
Plot No. 4246, GIDC, Dared,  
Phase - III, Road No. E,  
Jamnagar, Gujarat 361 004  
**India**

Additional  
manufacturing  
locations:

This certificate is issued as verification that a sample(s), representative of production, was assessed and tested and found to comply with the IEC Standard list below and that the manufacturer's quality system, relating to the Ex products covered by this certificate, was assessed and found to comply with the IECEx Quality system requirements. This certificate is granted subject to the conditions as set out in IECEx Scheme Rules, IECEx 02 and Operational Documents as amended

## STANDARDS :

The equipment and any acceptable variations to it specified in the schedule of this certificate and the identified documents, was found to comply with the following standards

**IEC 60079-0:2017** Explosive atmospheres - Part 0: Equipment - General requirements  
Edition:7.0

**IEC 60079-1:2014-06** Explosive atmospheres - Part 1: Equipment protection by flameproof enclosures "d"  
Edition:7.0

**IEC 60079-31:2013** Explosive atmospheres - Part 31: Equipment dust ignition protection by enclosure "t"  
Edition:2

**IEC 60079-7:2017** Explosive atmospheres - Part 7: Equipment protection by increased safety "e"  
Edition:5.1

This Certificate **does not** indicate compliance with safety and performance requirements other than those expressly included in the Standards listed above.

## TEST & ASSESSMENT REPORTS:

A sample(s) of the equipment listed has successfully met the examination and test requirements as recorded in:

Test Report:

[NO/PRE/ExTR20.0129/00](#)

Quality Assessment Report:

[NO/PRE/QAR20.0014/00](#)



# IECEx Certificate of Conformity

Certificate No.: **IECEx PRE 20.0124X**

Page 3 of 3

Date of issue: 2021-03-03

Issue No: 0

## **EQUIPMENT:**

Equipment and systems covered by this Certificate are as follows:

A range of compression type cable glands are manufactured in brass or stainless steel SS304 / SS 316L grade material. The glands may be supplied with metric or NPT thread forms. These glands are intended for use with effectively filled circular cables.

Type MM-EX A2F \*\* \*\* \*\* series cable glands are intended for use with effectively filled and circular unarmoured/ screened / braided cables and comprises following components:

1. An entry component
2. A compressible sealing ring
3. A skid washer
4. A back nut
5. O ring for metric threaded entry component

Type MM-EX E1FUNV \*\*\* \*\* \*\* series cable glands are intended for use with effectively filled and circular armoured cable and comprises following components:

1. An entry component
2. A compressible inner sealing ring
3. An inner skid washer
4. A combined intermediate body and armour clamping cone
5. A reversible armour clamping ring
6. A middle nut
7. A compressible outer sealing ring
8. An outer skid washer
9. A back nut
10. O ring for metric threaded entry component

Cable glands with metric threaded entry components are fitted with silicon O ring retained next to threaded part for ingress protection IP66 / IP68.

## **SPECIFIC CONDITIONS OF USE: YES as shown below:**

1. Cable glands are suitable for use within an operating temperature range of -55°C to +160°C.
2. Cables must be effectively clamped to prevent pulling and twisting for Type MM-EX A2F \*\* \*\* \*\* series of cable glands to ensure that pulling is not transmitted to the terminations.
3. The cable glands shall only be used with substantially round cables.
4. Cable gland must be installed in accordance with requirements of IEC 60079-14.

## **Annex:**

[Annex to certificate IECEx PRE 20.0124X\\_1.pdf](#)

Annex to certificate: IECEx PRE 20.0124X

**Type designation**

1. MM-EX A2F \*\* \*\* \*\* \*
2. MM-EX E1FUNV \*\*\* \*\* \*\* \*

**Coding and Model Nomenclature of MM-EX A2F \*\* \*\* \*\* \* series cable glands for unarmoured cable:**

Gland Size	Entry Thread		Cable Diameter in mm		Tightening Torque Value in Nm
	Standard (Metric)	Optional (NPT)	Minimum	Maximum	
20S16	M20 X 1.5	1/2" or 3/4"	3.2	8.5	11
20S	M20 X 1.5	1/2" or 3/4"	6.2	11.6	8
20	M20 X 1.5	1/2" or 3/4"	8.0	13.9	11
25	M25 X 1.5	3/4" or 1"	11.2	19.6	15
32	M32 X 1.5	1" or 1 1/4"	17.1	26.0	24
40	M40 X 1.5	1 1/4" or 1 1/2"	23.6	31.6	35
50S	M50 X 1.5	1 1/2" or 2"	31.1	37.5	46
50	M50 X 1.5	1 1/2" or 2"	35.7	43.1	41
63S	M63 X 1.5	2" or 2 1/2"	41.6	48.7	57
63	M63 X 1.5	2" or 2 1/2"	47.3	55.2	46
75S	M75 X 1.5	2 1/2" or 3"	54.1	61.2	90
75	M75 X 1.5	3" or 3 1/2"	61.2	67.2	68
90	M90 X 2	3 1/2" or 4"	66.7	79.2	101

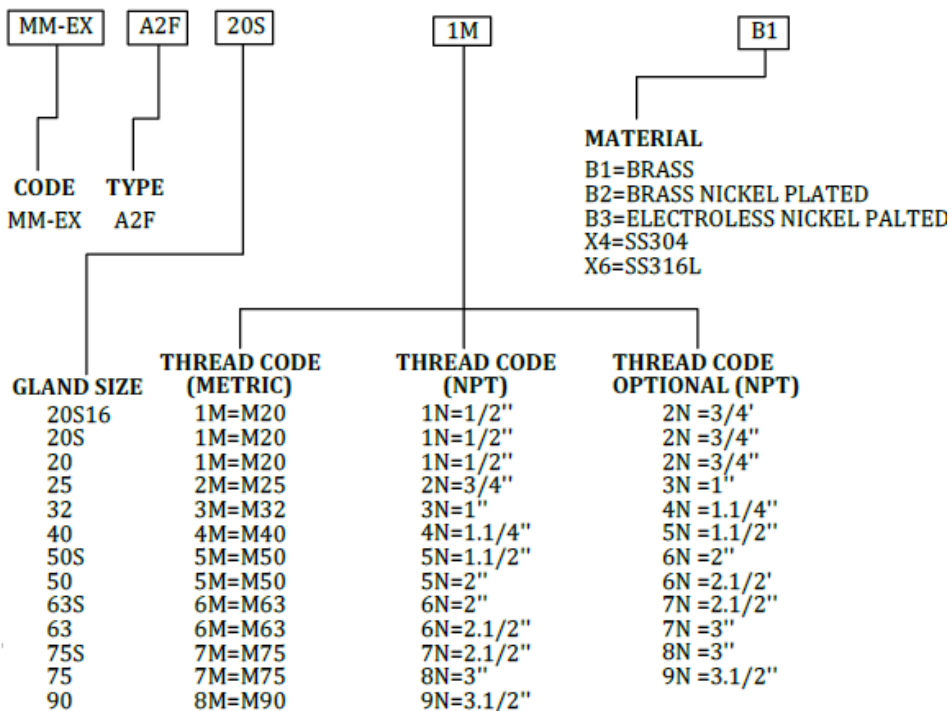

**Model Nomenclature of MM-EX E1FUNV \*\*\* \*\* \*\* series cable glands for armoured cable:**

Gland Size	Entry Thread		Inner Sheath Cable Diameter in mm		Outer Sheath Cable Diameter in mm		Tightening Torque Value in Nm
	Standard (Metric)	Optional (NPT)	Minimum	Maximum	Minimum	Maximum	
M20S16	M20 X 1.5	1/2" or 3/4"	3.2	8.5	6.2	13.1	15
M20S	M20 X 1.5	1/2" or 3/4"	6.2	11.6	9.6	15.5	10
M20	M20 X 1.5	1/2" or 3/4"	8.0	13.9	12.5	20.9	15
M25S	M25 X 1.5	3/4" or 1"	11.2	19.6	14	21.5	22
M25	M25 X 1.5	3/4" or 1"	11.2	19.6	18.3	25.6	22
M32	M32 X 1.5	1" or 1 1/4"	17.1	26.0	23.7	33.4	30
M40	M40 X 1.5	1 1/4" or 1 1/2"	22.1	31.6	28.0	39.5	52
M50S	M50 X 1.5	1 1/2" or 2"	29.5	37.5	35.2	46.0	66
M50	M50 X 1.5	1 1/2" or 2"	35.6	43.1	40.5	52.4	41
M63S	M63 X 1.5	2" or 2 1/2"	40.1	48.7	45.6	58.5	74
M63	M63 X 1.5	2" or 2 1/2"	47.2	55.2	54.6	64.5	63
M75S	M75 X 1.5	2 1/2" or 3"	52.8	61.2	59.0	70.4	112
M75	M75 X 1.5	3" or 3 1/2"	59.1	67.2	66.7	76.3	96
M90	M90 X 2	3 1/2" or 4"	66.6	79.2	76.2	87.2	137

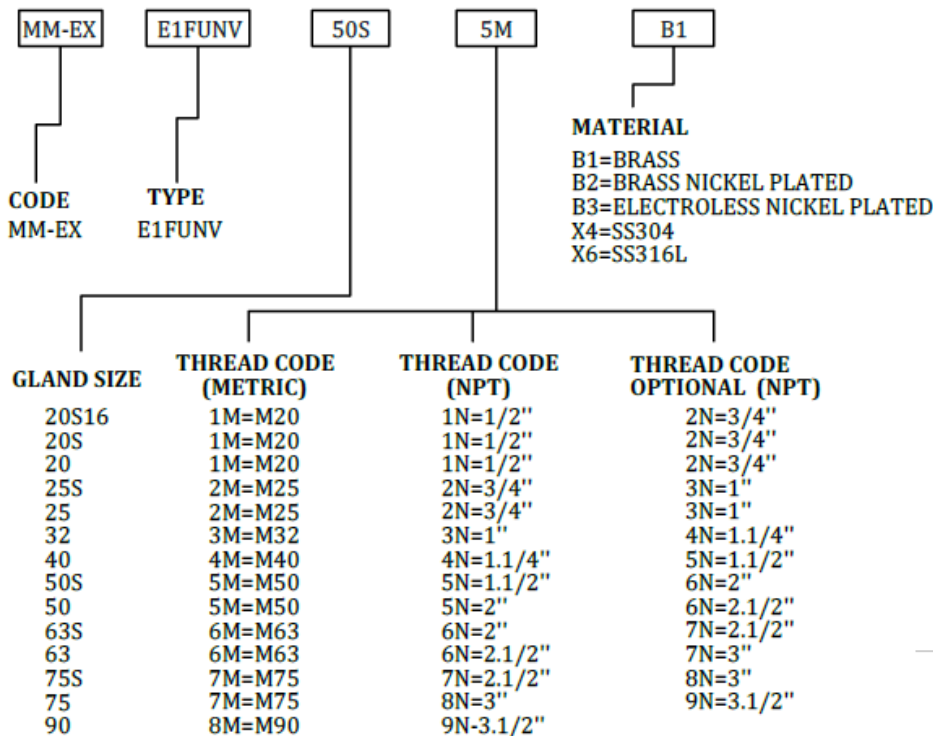

**Electrical Data**

---

Not Applicable

**Degrees of protection (IP Code)**

IP66/ IP68 (1.5 meter, 2 Hours)

**Ambient temperature:**

-55°C to +160°C

**Routine tests**

N/ A