



IECEx Certificate of Conformity

INTERNATIONAL ELECTROTECHNICAL COMMISSION IEC Certification System for Explosive Atmospheres

for rules and details of the IECEx Scheme visit www.iecex.com

Certificate No.: **IECEx PRE 20.0123X** Page 1 of 3 [Certificate history:](#)

Status: **Current** Issue No: 0

Date of Issue: 2021-03-03

Applicant: **METALMECH ENGINEERING**
Plot No. 4246, GIDC, Dared,
Phase - III, Road No. E,
Jamnagar, Gujarat 361 004
India

Equipment: **Stopping Plugs, Reducers & Adaptors**

Optional accessory:

Type of Protection: **Ex d, Ex e, Ex t**

Marking: **Ex db IIC Gb**
Ex eb IIC Gb
Ex tb IIIC Db

Ambient temperature: -55°C to +160°C

Approved for issue on behalf of the IECEx
Certification Body:

Asle Kaastad

Position:

Certification Manager

Signature:
(for printed version)

Date:

1. This certificate and schedule may only be reproduced in full.
2. This certificate is not transferable and remains the property of the issuing body.
3. The Status and authenticity of this certificate may be verified by visiting www.iecex.com or use of this QR Code.



Certificate issued by:

DNV Product Assurance AS
Veritasveien 3
Hovik 1363
Norway





IECEx Certificate of Conformity

Certificate No.: **IECEx PRE 20.0123X**

Page 2 of 3

Date of issue: 2021-03-03

Issue No: 0

Manufacturer: **METALMECH ENGINEERING**
Plot No. 4246, GIDC, Dared,
Phase - III, Road No. E,
Jamnagar, Gujarat 361 004
India

Additional
manufacturing
locations:

This certificate is issued as verification that a sample(s), representative of production, was assessed and tested and found to comply with the IEC Standard list below and that the manufacturer's quality system, relating to the Ex products covered by this certificate, was assessed and found to comply with the IECEx Quality system requirements. This certificate is granted subject to the conditions as set out in IECEx Scheme Rules, IECEx 02 and Operational Documents as amended

STANDARDS :

The equipment and any acceptable variations to it specified in the schedule of this certificate and the identified documents, was found to comply with the following standards

IEC 60079-0:2017 Explosive atmospheres - Part 0: Equipment - General requirements
Edition:7.0

IEC 60079-1:2014-06 Explosive atmospheres - Part 1: Equipment protection by flameproof enclosures "d"
Edition:7.0

IEC 60079-31:2013 Explosive atmospheres - Part 31: Equipment dust ignition protection by enclosure "t"
Edition:2

IEC 60079-7:2017 Explosive atmospheres - Part 7: Equipment protection by increased safety "e"
Edition:5.1

This Certificate **does not** indicate compliance with safety and performance requirements other than those expressly included in the Standards listed above.

TEST & ASSESSMENT REPORTS:

A sample(s) of the equipment listed has successfully met the examination and test requirements as recorded in:

Test Report:

[NO/PRE/ExTR20.0128/00](#)

Quality Assessment Report:

[NO/PRE/QAR20.0014/00](#)



IECEx Certificate of Conformity

Certificate No.: **IECEx PRE 20.0123X**

Page 3 of 3

Date of issue: 2021-03-03

Issue No: 0

EQUIPMENT:

Equipment and systems covered by this Certificate are as follows:

Stopping plugs, Type MM-EX PLG** ** are manufactured in brass or stainless steel SS304 / SS 316L grade material comprises a solid plug with an external thread form as indicated in below type nomenclature.

MM-EX PLG *M ** type stopping plugs are mushroom head plugs used for blanking un-used metric entries in the Ex certified equipment. The head plug is tightened with the use of an Allen key on the external hexagon recess. The mushroom head stopping plug is fitted with silicone O-ring secured in a groove under the head of the stopping plug for ingress protection IP66 / IP68.

MM-EX PLG *N ** type stopping plugs are shoulder less cylindrical plugs with external threads along their length used for blanking un-used NPT entries in the Ex certified equipment. The head contains hexagonal recessed socket to allow fitting and removal.

Adaptors Type MM-EX AD** ** ** and Reducers Type MM-EX RD** ** ** are manufactured in brass or stainless steel SS304 / SS 316L grade material comprises a hollow hexagonal body with male and female coaxial threads.

When structured as an adaptor, the female thread is larger than the male thread. When structured as a reducer the female thread is smaller than the male thread.

The adaptors and reducers with male cylindrical metric threads are fitted with an O ring mounted in a groove in the face of the hexagon on the male thread side for ingress protection IP66/ IP68.

SPECIFIC CONDITIONS OF USE: YES as shown below:

1. Stopping plugs must not be used with a thread adaptor or reducer in flameproof applications.
2. O ring must be trapped between the enclosure face and the head of the mushroom head metric threaded stopping plugs and hexagonal face of the metric threaded reducers and adaptors to ensure ingress protection level of IP66/ IP68 (1.5 meter below the surface of water for 2 hours).
3. The service temperature of the stopping plugs, reducers and adaptors is limited to -55°C to + 160°C.
4. The stopping plugs, reducers and adaptors should be tightened to the torque declared in the installation instructions.
5. When the stopping plugs, reducers and adaptors are used for increased safety or dust protection in a plain hole, the hole in the enclosure must not be greater than 0.5mm above the major diameter of the male thread and the stopping plugs, reducer and adaptor must be secured with a locknut. The female threads of the reducer and adaptor are to be sealed, in accordance with IEC 60079-14, to maintain the ingress protection rating of the associated enclosure.
6. When the stopping plugs, reducers and adaptors are fitted in threaded holes, the sealing face of the enclosure shall be smooth, the threaded hole shall be perpendicular to the wall of the enclosure, The female threads of the reducer and adaptor are to be sealed, in accordance with IEC 60079-14, to maintain the ingress protection rating of the associated enclosure.

Annex:

[Annex to certificate IECEx PRE 20.0123X_1.pdf](#)

Annex to certificate: IECEx PRE 20.0123X

Type Designation

1. MM-EX PLG ** **
2. MM-EX RD ** ** **
3. MM-EX AD ** ** **

Model Nomenclature of Stopping Plugs:

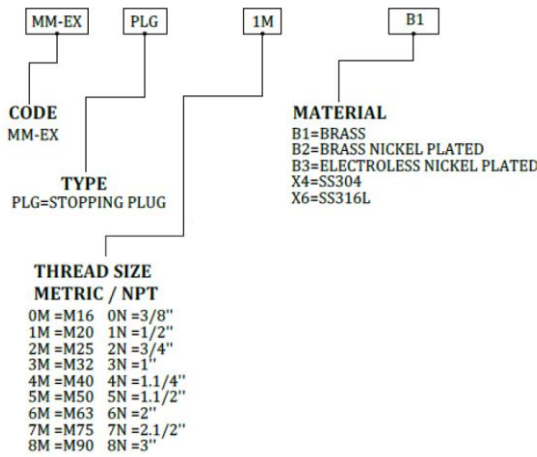

Model Nomenclature of Reducers:

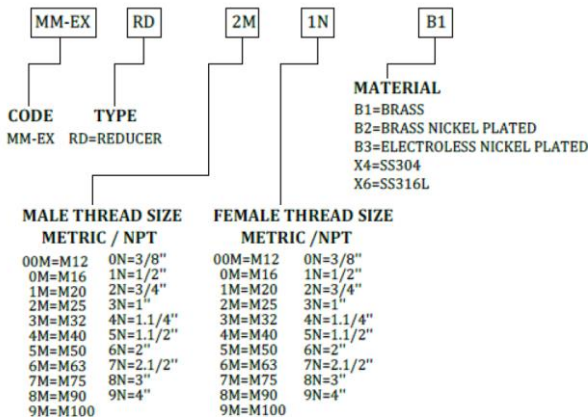

Model Nomenclature of Adaptors:

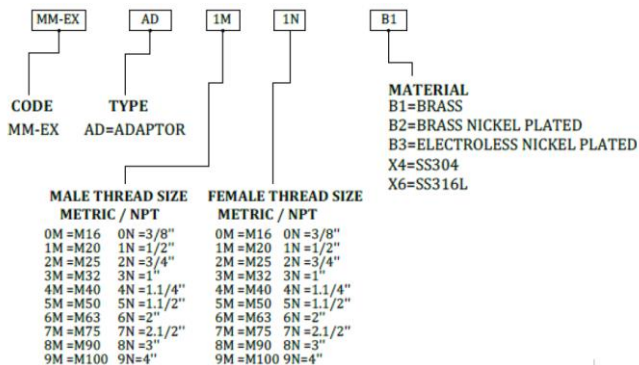

Electrical Data

Not Applicable

Degrees of protection (IP Code)

IP66/ IP68 (1.5 meter, 2 Hours)

Ambient temperature:

-55°C to +160°C

Routine tests

N/ A